



WARBIRDKITS.COM

Cutlass F7U-3M

Manual Version 1.1 – January 2011

Scale: 1:15
Wingspan: 30.75 inches
Area: 256 square inches
Power: 66mm EDF

Original Design by Roger Winger
Re-Engineered by Tom Jacoby
Developed by Steve St.Martin
Produced by Warbirdkits.com
Copyright 2010 Thomas A. Jacoby



Cutlass F7U-3M

Introduction by Steve St.Martin

Greetings Modeler: Thank you for purchasing, probably, the best flying EDF you will ever own! While the jet is not hard to build, it does require some experience in balsa working. I have been building and flying models for 51 years, and every now and then a design shows itself that simply amazes me. I built the first prototype Cutlass in the late winter of "08". Test flights were late spring. It has flown two seasons and still thrills me with its wide envelope of flight. It will fly so slow you will get bored. Or, so quick that the verticals never seem to stop. On a recent video, 75% power resulted in a 95mph pass.

It can be flown as tight-in as a second prop trainer, or wide maneuvers that are full scale. Roll rate can be so fast it's hard to count. I have yet to stall it into a snap. Stalls are just a mush and loss of altitude. Because of the very low frontal area, she will glide forever. 25% power will fly the jet with a 500W system. I get consistent launches with 10 pounds pull on the bungee, 50% fan power, and holding 50% up elevator.

The all-up weight (AUW) of the first prototype was 34 ounces. This was with an old (but new) Astro 805W (3700Kv), CC Phoenix 45, WeMoTec Minifan and Excite 2200-4S LiPo battery, external BEC. Because of balancing problems, I decided to use the smaller WeMoTec "505" fan. This fan can be moved over an inch rearward, due to the smaller diameter. But also, the lower amp draw and higher efflux speed of the smaller fan were just ideal for this design.

There are two build threads on rcgroups.com. If you're not a member, join and then do a search on "Cutlass". Join in on the thread. Show us your progress, ask questions, and show us your ideas. Warbirdkits.com is always open to good safe ideas.

While I try to cover all areas in this manual, experience will produce the best airframe. There is only so much prefab that can be done with this type. Some parts may have to be sanded slightly for a good fit. Or some may need filling with scrap to achieve the best fit. If you take your time and use your honest best effort, you will be rewarded with an airframe that not too many people (now-a-days) can say they built. The pride of seeing your creation flying overhead beats "hands-down" any foam or fiberglass airframe that are other people's effort.

The prototype was covered completely with 0.5 oz cloth and epoxy finishing resin. Covering is of your choice, for what you like to use. If flying from grass, silkspan and dope will give a very light weight finish. Doculam laminating film is also an excellent choice. Rougher surfaces will require bottom protection. Packing tape will help here. I like using Tamiya, Krylon, and Model Master paints.

Because this is a short kit, it is highly advised to use the lightest wood you can find. I suggest using a contest type from National Balsa (www.nationalbalsa.com). They have a second-grade contest that has blemishes only, and they offer great prices and service.

Adhesives are your choice. My preferences vary according to application. I use all grades of CA, aliphatic resin, epoxy, and Pro-Bond or Gorilla urethanes. But use adhesives sparingly. Extra glue only adds weight, not strength.

Please pay attention to all notes [NOTE:]. I put these in to help you avoid certain pitfalls that may come up later, in the build. There will also be tips [TIP:] that are just ideas that I have learned over the years. They are not critical to the build, and you may have a better way.

So... let's get your Cutlass in the air!

Steve St. Martin

A Note on Language: When introduced into service in 1954, the Cutlass featured "ailevators" for roll and pitch control. The modern term for ailevator is "elevon" and that's the term we use in this manual.

Building the Cutlass

Materials Needed

- * 1/32" x 4" x 36" Balsa sheet – 1 each
- * 1/16" x 3" x 36" Balsa sheet – 4 each
- * 3/32" x 3" x 36" Balsa sheet – 4 each
- * 1/4" x 4" x 36" Balsa sheet – 1 each
- * 1/64" x 4" x 36" Ply sheet – 1 each
- * 1/8" square Spruce stick – 1 each
- * 1/4" square Spruce stick – 1 each
- * 3/16" Aluminum Tube or Arrow Shaft
- * 3/32" Diameter Carbon Rod
- * 3/32" Inner Diameter Aluminum Tube
- * .032" Music Wire
- * 2/56 Threaded Couplers
- * Small Nylon Clevis – 2 each
- * 3/16" Rare Earth Magnets – 8 each

Step 1: Wing Skin Assembly

Lay out the bottom wing skins as shown. Make a left and a right panel.

Use these parts to make the top skins from builder supplied 1/16x3" sheet. [NOTE:] The top wing panel skins need to be 1/4" - 3/8" wider, chord-wise – than the bottom skins. Join bottom wing sheeting with masking tape. Do the same with top sheeting. [TIP:] Always place the tape on what will be the outer surface of the sheeting. This will mean less sanding later, for a smooth and true surface.

While bending the sheeting at the taped joint, run a fine bead of white glue into the seams. Lay the sheeting flat and wipe off excess. Repeat on all panels. Lay the panels on top of one another, on flat surface with waxed paper

between, underneath and on top of the panels. Weight down the panels and let cure.

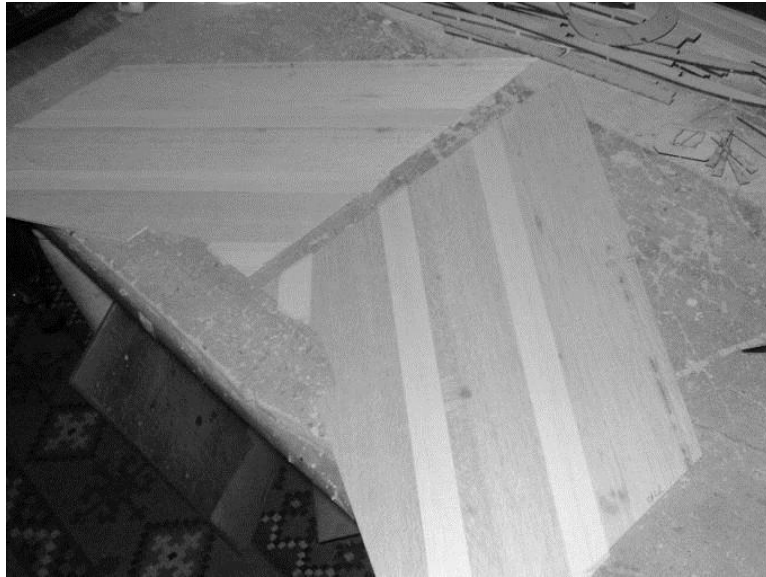

Step 2: Vertical Stabilizer Assembly

Assemble the vertical stabilizers, as shown, on a waxed paper surface. Before adding the side doublers, bevel the top edge to blend with the core. This is easier done now. Attach the doublers with thick CA, making sure wing cutout is in line with the core. Sand the vertical stabilizers, round the LE, and taper the TE of the core and doublers. Model Magic can be used to fine blend the doublers into the cores.

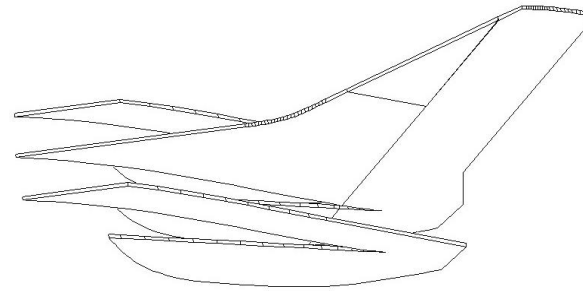

Step 3: Bulkhead Preparation

Bulkheads F5, F6, F7, and F9 are laminations.

F6 and F7 consist of 1/16" outer layers, with a 1/8" balsa core. Note that there are small holes in the F6 and F7 parts – insert round tooth picks through these holes to align the parts. Just keep the thick CA away from the tooth pick holes. Join the 1/16" top and bottoms, and pin to a waxed surface with the round tooth picks in place. Be sure to orient the pieces for top and bottom. Add the 1/8" balsa bulkhead core. Note that there is a 1/8" slot left. This is for the 3/32" ID aluminum tube that will receive the 3/32" carbon dowel wing joiners. Next add the outer 1/16" bulkhead. Cut lengths of the 3/32" ID aluminum tube, roughen the outside and insert into the bulkheads. They should be flush with the inside edge of the bulkheads and protrude 3/32" outside the bulkhead. Wick some medium CA onto the outside of the aluminum tubes to secure them.

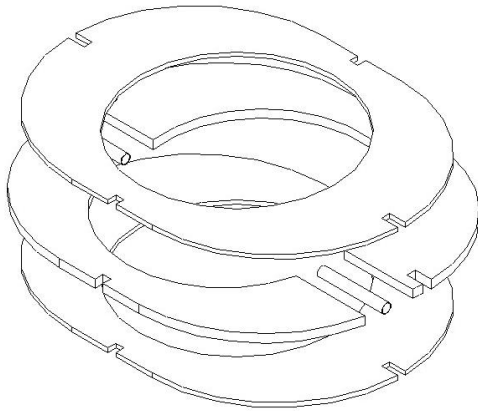

The F5 bulkhead is a lamination of 1/16" balsa and 1/16" ply. Remove the inlet portions from the balsa F5. DO NOT remove the inlet portions from the ply F5. Glue the F5 bulkheads together. For future note, the plywood side is forward.

Laminate F9 from two 1/16" plywood pieces.

Step 4: Fuselage Assembly

Make a fuselage assembly table at least 18" long by 10" wide. It must be very flat. Draw a line down the middle of the table.

Assemble the F5 and F9 bulkhead uprights with their angle braces. The angle braces will only fit the correct verticals. Be sure to make the angle braces 90 degrees to the verticals.

Glue F5 upright flush with the front of the jig table, with its center line on the table's center line. Glue F9 upright exactly 15-3/8" back from the front of the F5 upright, and with its center line on the table's center line.

Use toothpicks to align bulkhead F9 against F9 upright, with a piece of wax paper sandwiched between.

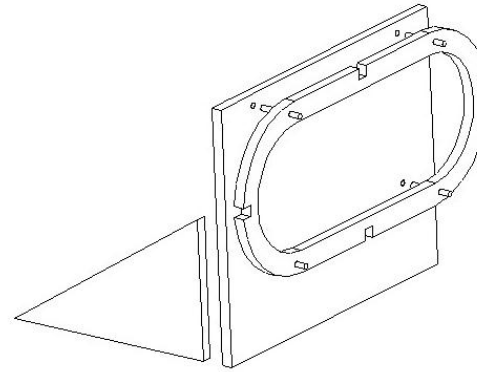

Step 5: Nose Section Assembly

Glue the two crutch CN parts together on a flat surface.

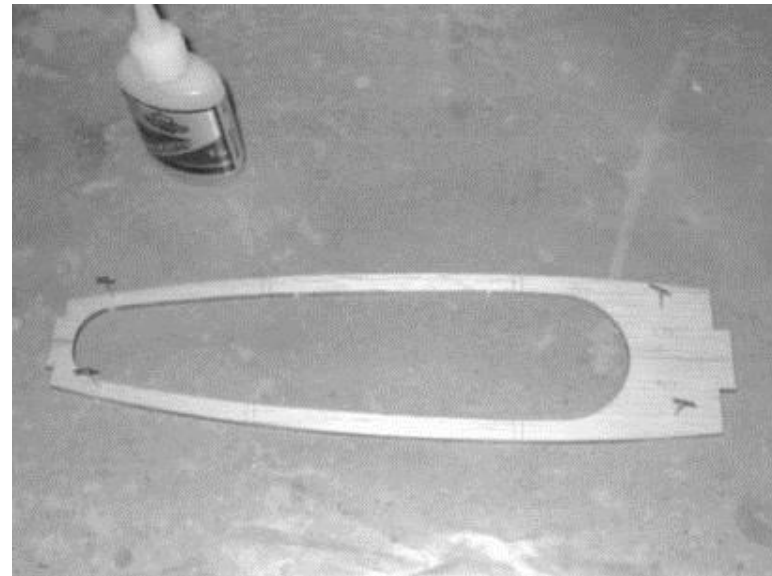

Glue bulkheads F1, F2 and F3 in place. Glue the bottom of F4 to crutch CN. Be sure the bulkheads are 90 degrees to the crutch CN.

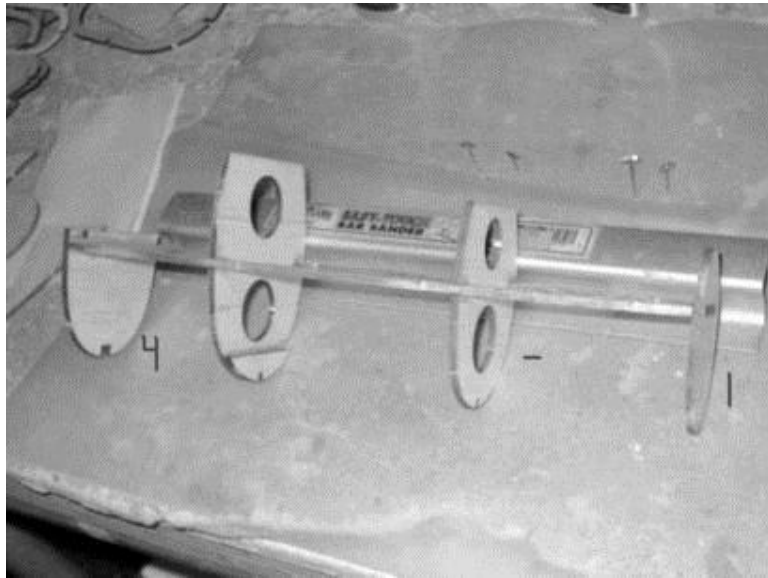

Glue the 1/8" square spruce bottom longeron and double 1/4" spruce bungee hook mount in place.

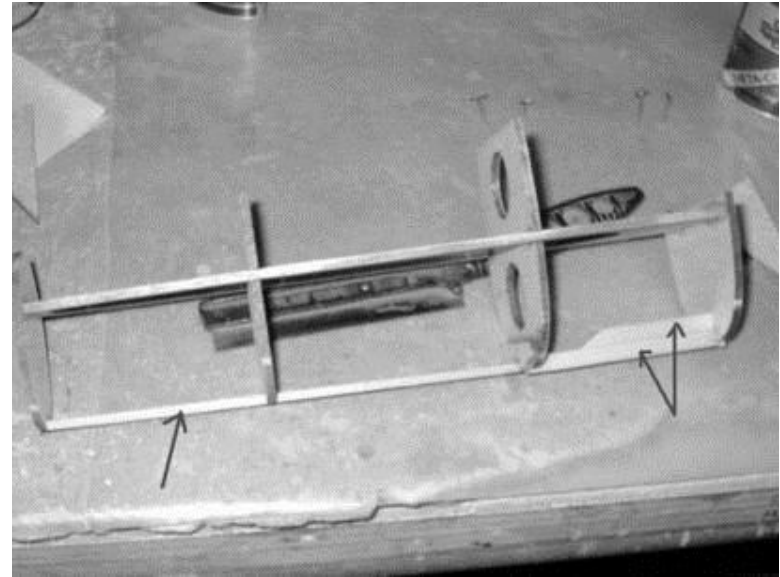

Glue bulkhead F5, with the ply side forward, to the rear of F4. Note that F4 is smaller than the radius of the F5 inlet. This is to facilitate the planking.

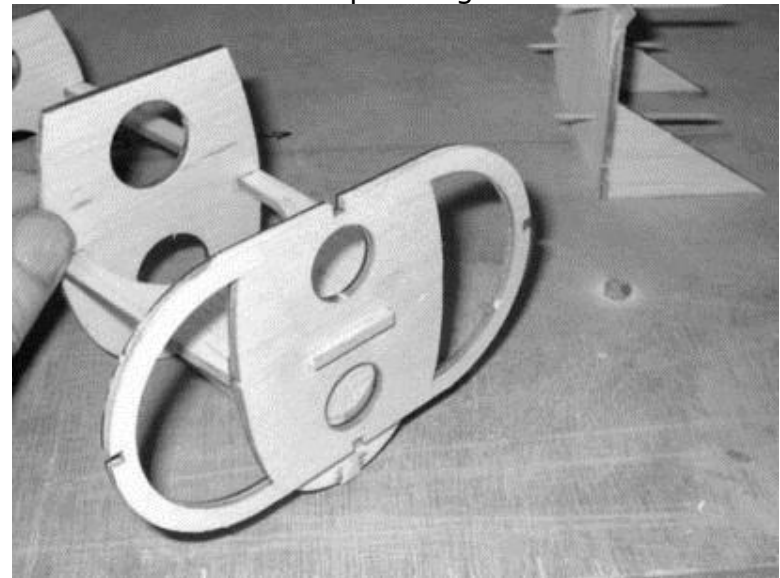

Place the nose assembly on upright F5 using clothespins to hold it in place. Note how the crutch CN has a slot in F5 upright to receive it.

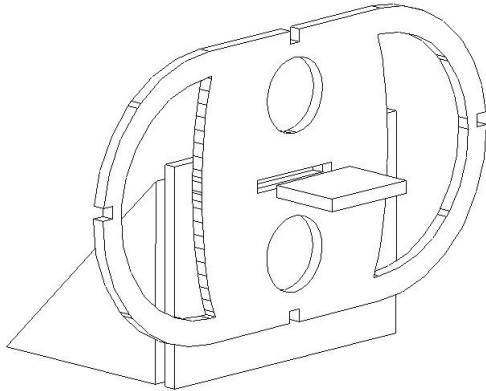

Insert bulkheads F6 and F7 into slots of top keel K1, but do not glue! Be sure bulkheads are upright and F7 has fan mount slots to the rear.

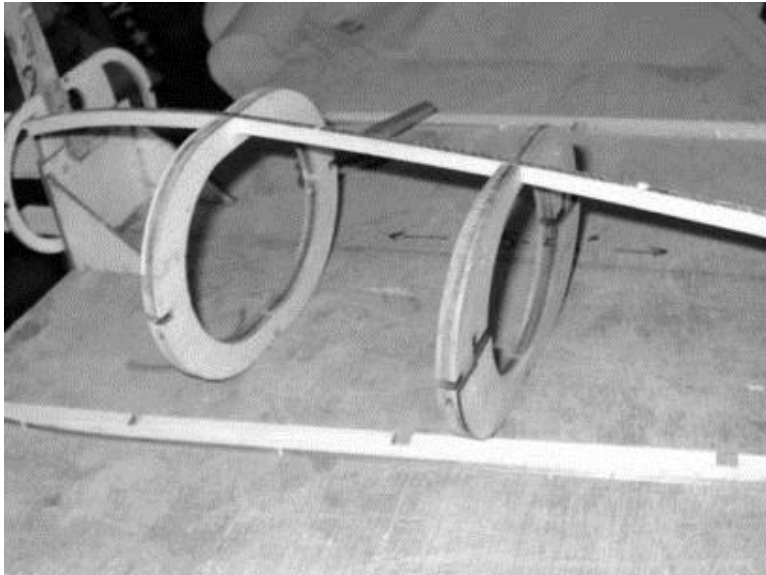

Insert keel K1 into position in F5 and F9.

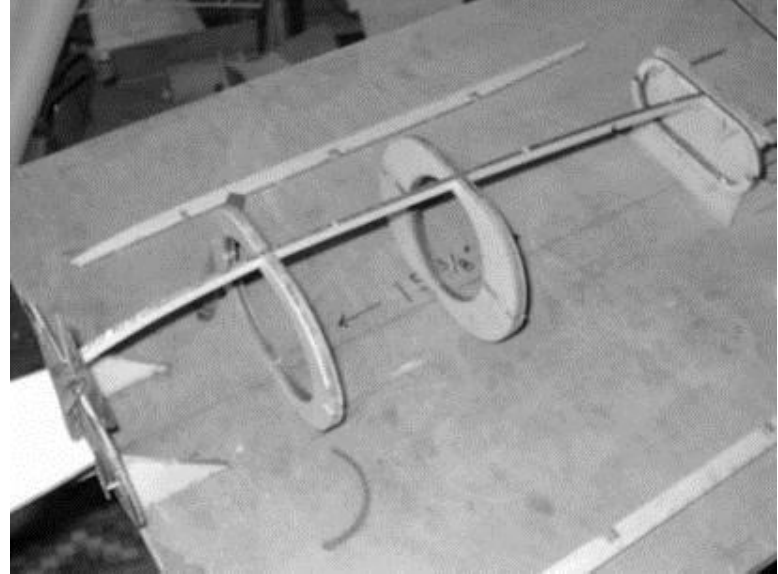

Add F8. Insert crutches CR and CL into notches of bulkheads F5, F6, F7, F8 and F9. Slight trimming of the keel notches at the end may be necessary. When satisfied with the alignment, glue with thin CA. [NOTE:] Be careful not to CA to the F5 upright! Your jet will not fly well with it sticking out the bottom.

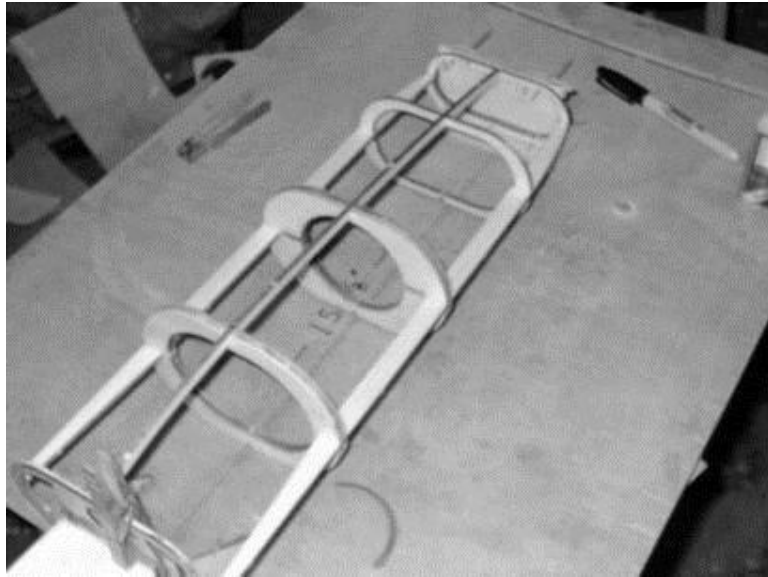

Remove the fuselage from the jig. You may need to use a single edge blade to gently pry it away from the uprights. Turn fuselage over and add bottom keel K2.

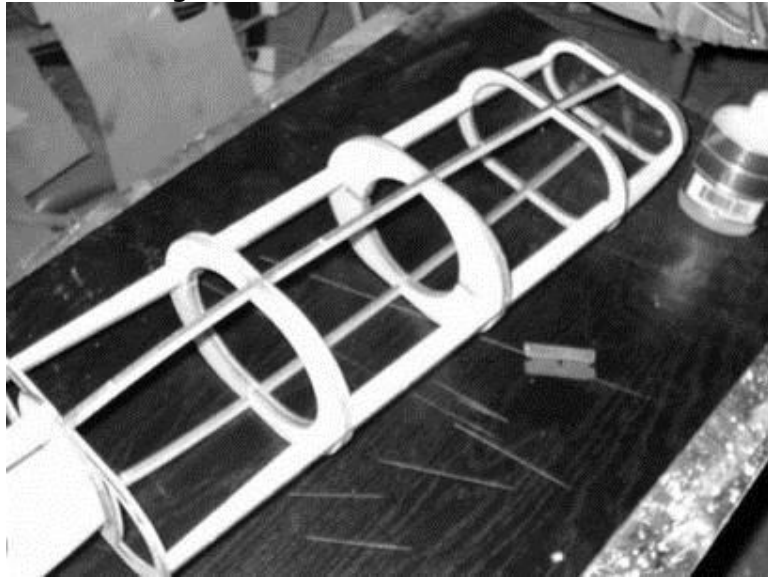

Step 6: Make the Hatch Frame

F7H is a lamination of 1/8" balsa and 1/16" ply. The ply side faces bulkhead F7.

F9H is 1/8" balsa. Insert these hatch bulkheads into position and install hatch keels HK1 and HK2. Hold the parts together with clothespins.

Use thick CA sparingly in all joints. Don't glue the hatch parts to the main structure.

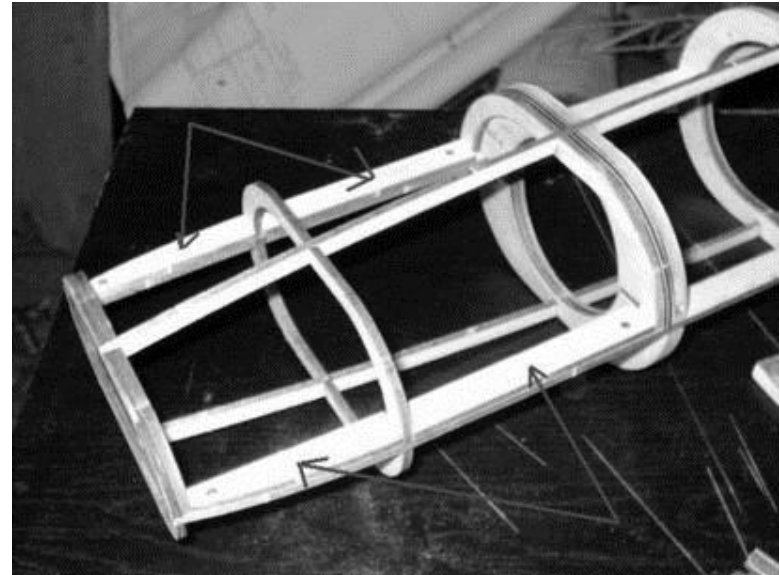

Remove the clothespins and drill out the magnet holes with a 1/8" drill. The holes will need to be enlarged to 3/16" with a round file.

Step 7: Begin Planking the Fuselage

Cut the 3/32" balsa sheet into 1/4" wide strips. [TIP:] If you don't have a balsa stripper, I highly suggest a Master Airscrew balsa stripper. [NOTE:] Cut one sheet into lengths that match the length from F5 to F9. Then strip this into 1/4" wide strips. Strip planking is an acquired learning process. So here a few tips to help. Start at the center of the top keel and glue one strip on each side of center. Repeat on the bottom keel. Glue one strip on the top center of each side keel. When you add a strip, always add another strip on the opposite side of the fuselage, working one-for-one side-to-side. After gluing strips on both sides of the keels, split the space between the keels with a strip applied in a straight line. Then gradually fill in the spaces by splitting the open areas. Finally you will have to taper ends and reduce strips in width. Be cautious around the hatch. You don't want to glue the hatch to the fuselage. As you apply a strip over the hatch seam, cut the seam. The seam is hard to find after full planking is done.

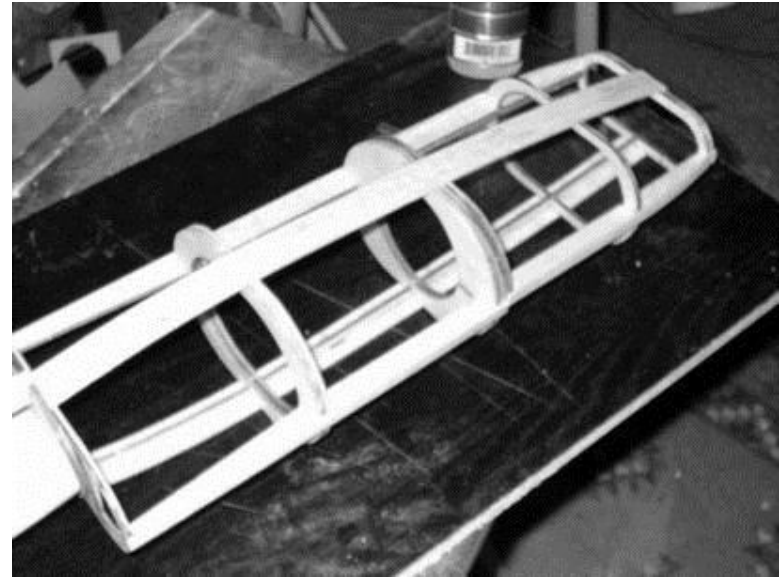

With these basics in mind, stop planking after the keel strips are in place. Remove the hatch by cutting through K2 and the planking at F7 and F9.

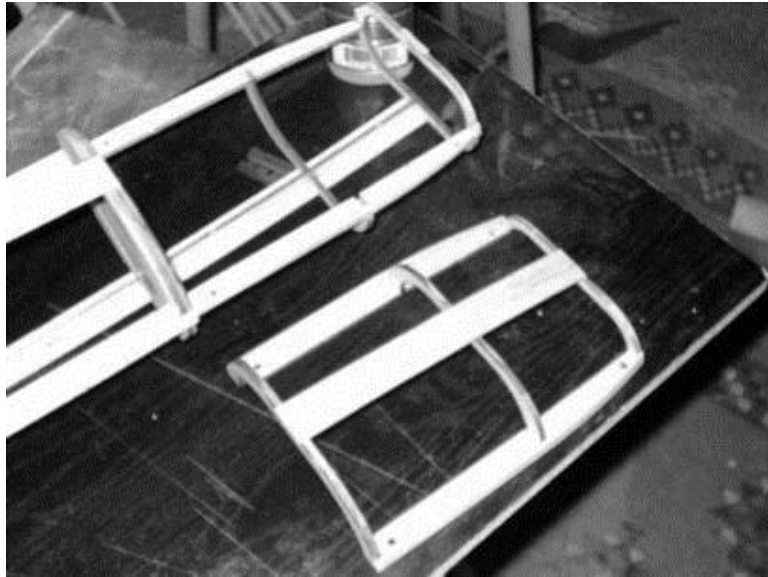

Step 8: Install the Fan

The WeMoTec 505 Pro comes with a carbon shroud assembled, but you must add the mounting ears. Other alternatives in 66mm sized fans are up to the modeler. A Minifan or other 69mm fan is a viable option but you will have to resize the inlet ducting to fit.

Laminate the 1/16" ply fan mounts. Add a 1/8" square spruce spacer on keels CR and CL.

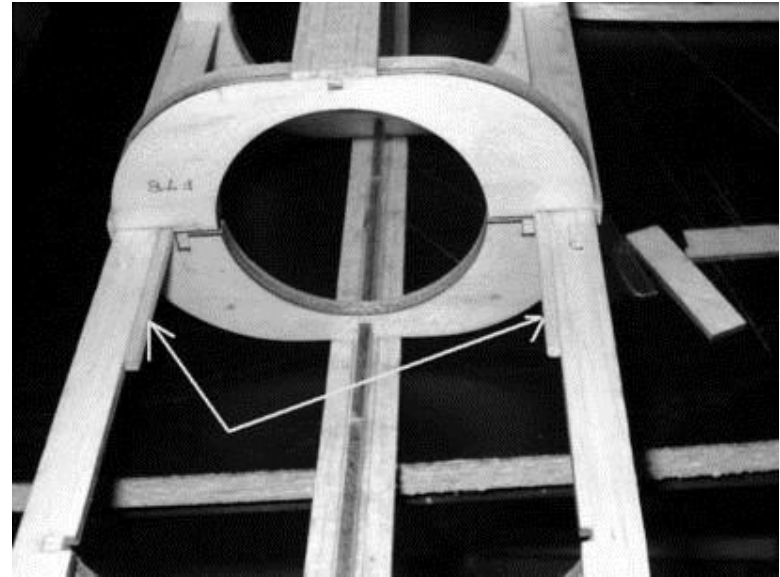

Lightly tack the fan bearers into position. Mount the fan to the bearers. I used 4-40 cap screws and tapped the bearers. Be sure the fan is centered in F7 and about 1/2" behind F7. After mounting the fan, finish gluing fan bearers into place. Recessing K1 and K2 is most likely necessary to clear fan and thrust tube.

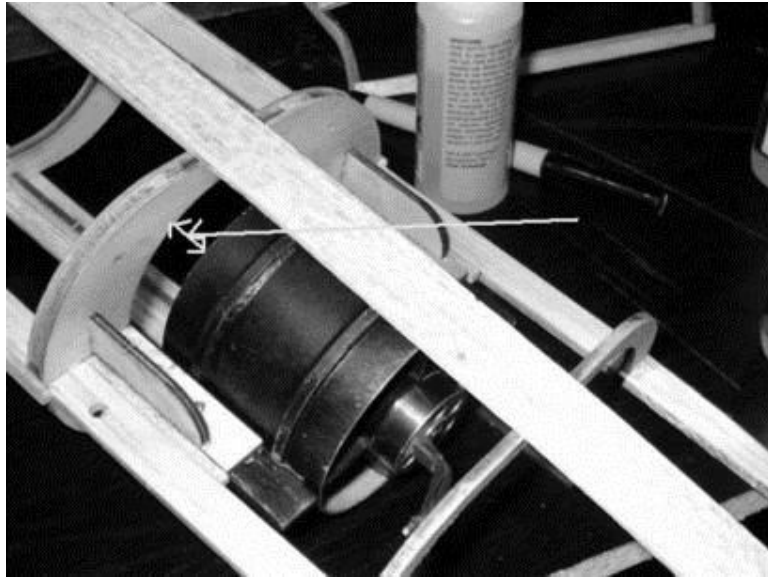

Remove the fan.

Step 9: Make the Inlet Ducting

This is really quite a simple task. DJ-1 duct form is slightly oversized. It must closely fit the outside of the fan shroud, with a $3/32$ " slot in the center. Use a sanding block to trim DJ-1 as needed. Tack-glue DJ-1 to the shroud. The slot MUST be perfectly vertical to the fan mounting. Mount the fan.

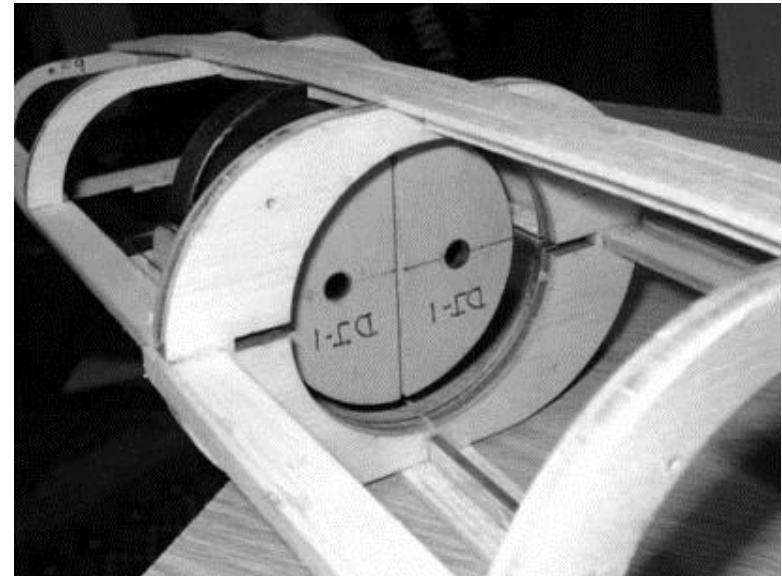

Cut lengths of 3/16" aluminum tubing or arrow shafts to fit through DJ-1 and inlet forms. Glue the tubing in place with thick CA. These are your duct jigs.

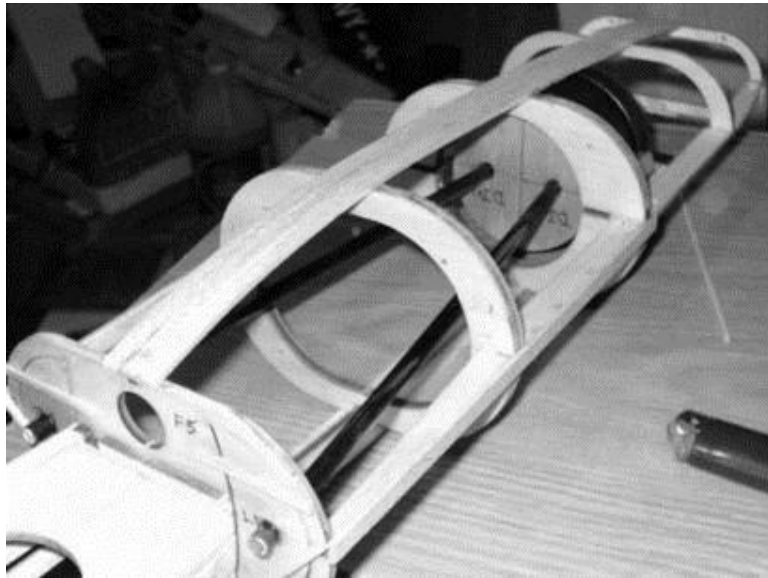

Cut loose the inlet forms from F5, and cut DJ-1 free from the shroud. Remove the fan. Remove the duct jigs through rear and mark them left and right. Remember that the fuselage may be upside down.

The flat portion of the ducting is a lamination of 1/32" balsa and 1/64" plywood. Note that the balsa piece is 5/32" longer at the intake end. This allows the 1/64" plywood piece to butt against the rear of F5. Be sure to make a left and right duct. The ducts are a mirror image of each other. Test fit parts to get opposites. Use the duct jigs to decide which is left and right. The balsa goes on the inside (jig side) of the duct.

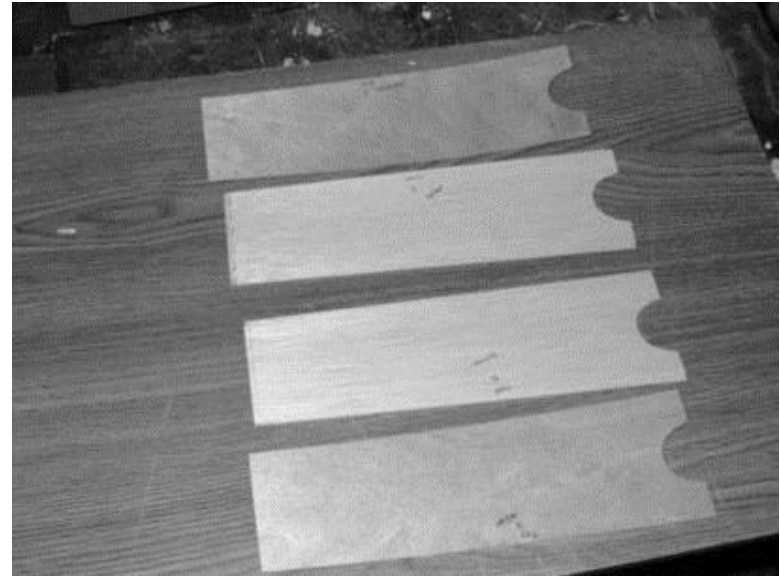

Use thick CA and position the laminates carefully. Add two 1/8" square spruce stiffeners to the fan end, the first about 2" from the end, and the second about 4" from the end.

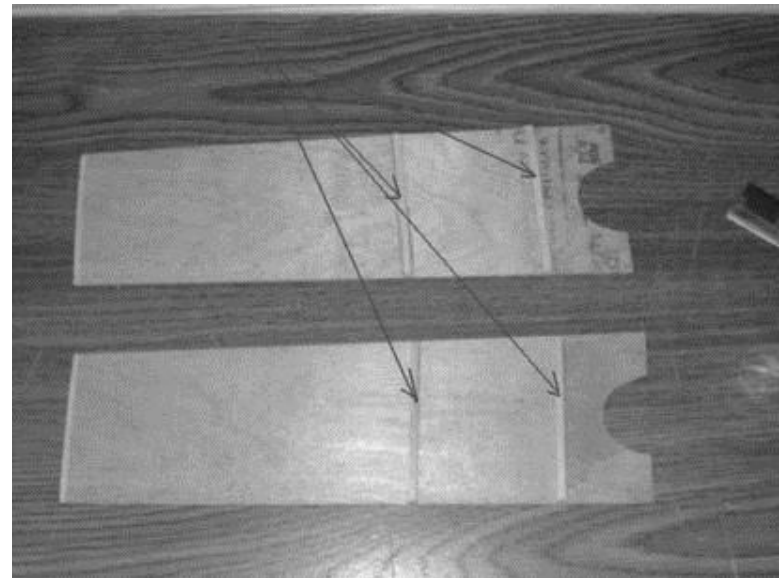

Trial fit these pieces to the fan for spinner clearance. Check against DJ-1 for height. If the pieces need trimming in height, do it equally top and bottom and transition smoothly to the inlet end. I purposely made these slightly oversized, as some shrouds may be thicker.

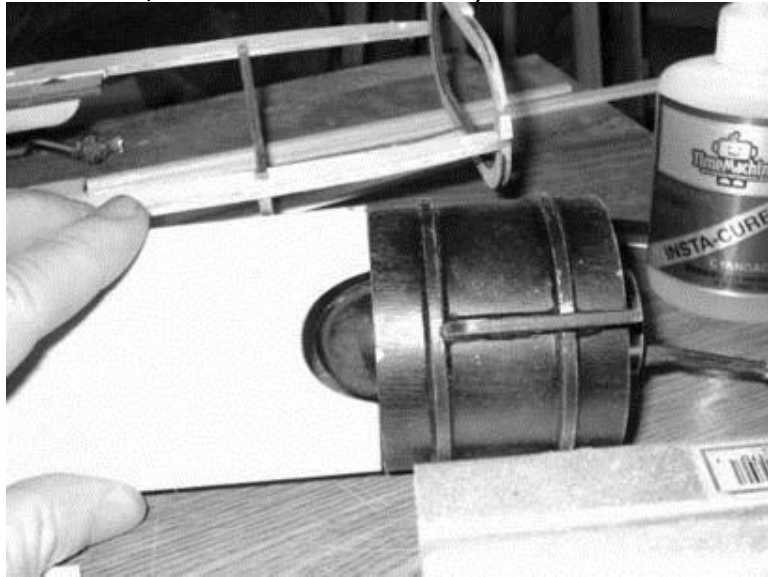

The 1/8" square corners may need to be chamfered slightly. Then CA one edge of the flat duct piece to the 1/64" ply outer piece.

Sand a piece of 1/8" square balsa to a semi triangle. These are attached to the edges of the flat ducting (balsa side), length-wise. They leave a gap of 1/8" at both ends. These clean the air flow in the duct corners.

Spray a coat of Krylon satin clear on the balsa side and lightly sand. Tack-glue the jigs to the duct pieces. They can only fit the correct one. Notice that the duct piece now has a twist. Locate the 1/64 ply outer duct pieces. Decide which is left and right, mark them and give these a coat of sanded Krylon. Do this lightly so as not to cause warps.



Then roll tightly. Check to see there are no gaps around the forms. Then secure the other side.



Strip off 18 pieces of cross-grained 1/64" plywood, 1/8" wide. These form the laminate stiffeners for the ducting. They begin 1" from the fan end, next at 3-1/2", then half way to the inlet. (The ones in the photos are too far back near the fan. Use these numbers.) Each laminate is 3 strips. These hold the duct in correct shape, and make the ducts implosion-proof.

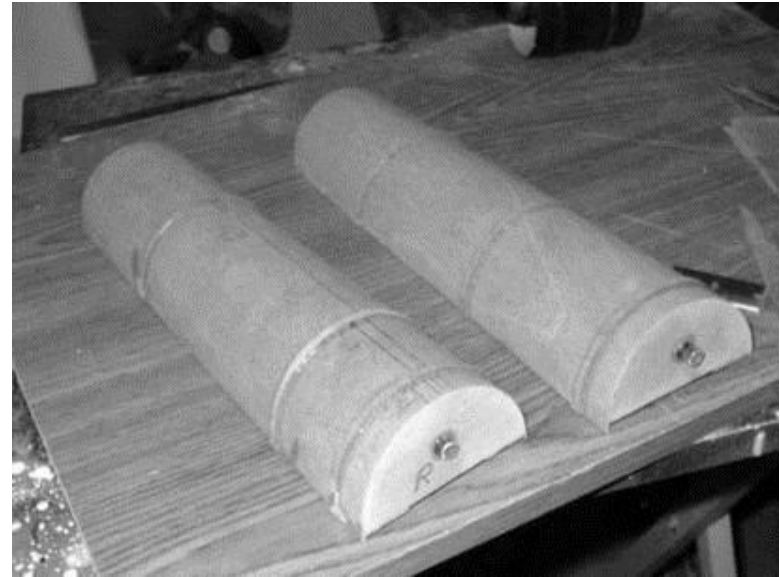

Now trim the curved duct pieces to match DJ-1, leaving 3/32" excess to go over fan.

Now cut the tacks for the inlet and DJ-1 forms and remove the jig through the fan end. If this is the first time you made ducting, CONGRATULATIONS! Now you can make them anytime you want!

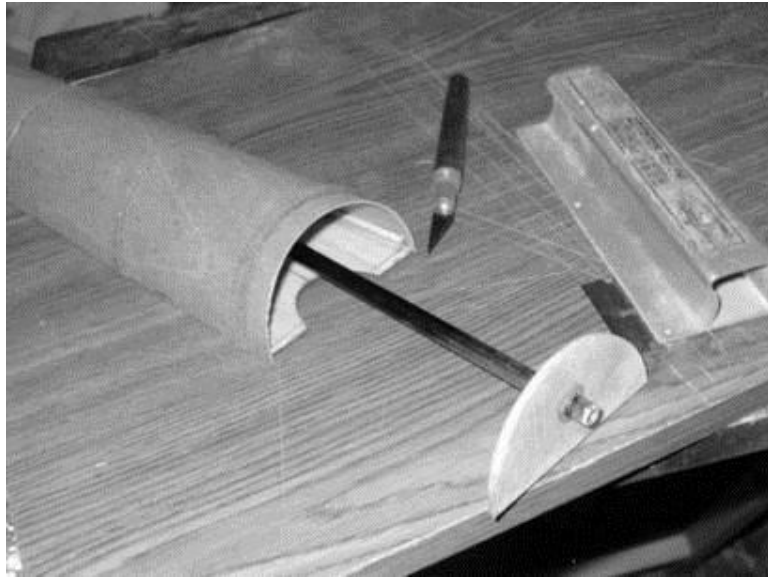

Step 10: Install the Ducting

You may have to trim the laminated stiffeners as shown, at the fan end, and at the intake, to fit into F5. Take your time and get a good fit. Because they enter F5 at an angle, they may need trimming as shown.

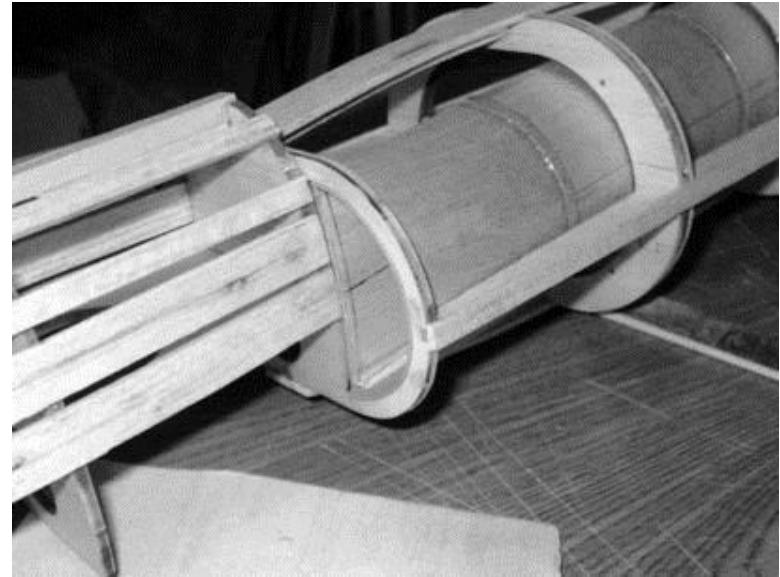

Trim F6 slightly as needed to clear the ducting.

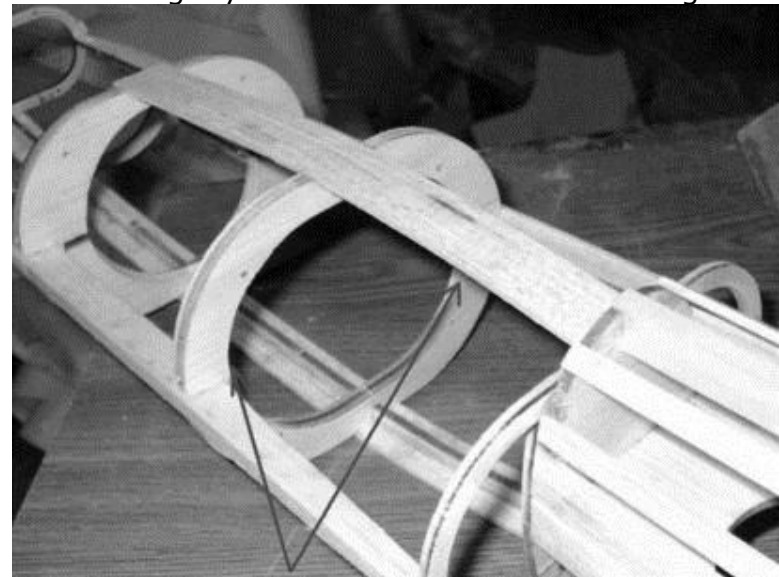

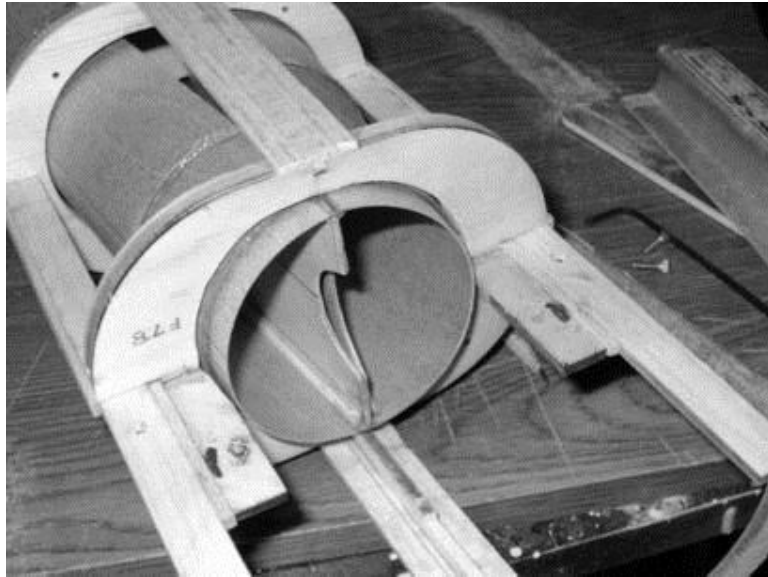

When satisfied with the fit of both ducts and they join together good at the fan end, install the fan into the ducting, and bolt the fan in. Check everything and CA the ducting to the frame at the inlet.

Strip off a length of 1/64" plywood cross-grain, to go around the fan and ducting, 3/8" wide. Secure to the ducting ONLY.



Glue the ducting to the fuselage wherever possible. A little scrap may be necessary. The ducting is now complete. It is suggested that all wiring for the fan, elevons, BEC, and ESC be done now. Cover the wire ends and connectors with tape to keep them clean.

Step 11: Make a Working Hatch

Cut eight 1/16" balsa epoxy dams for the magnets. They go on the hatch as shown and under the holes in CR and CL.

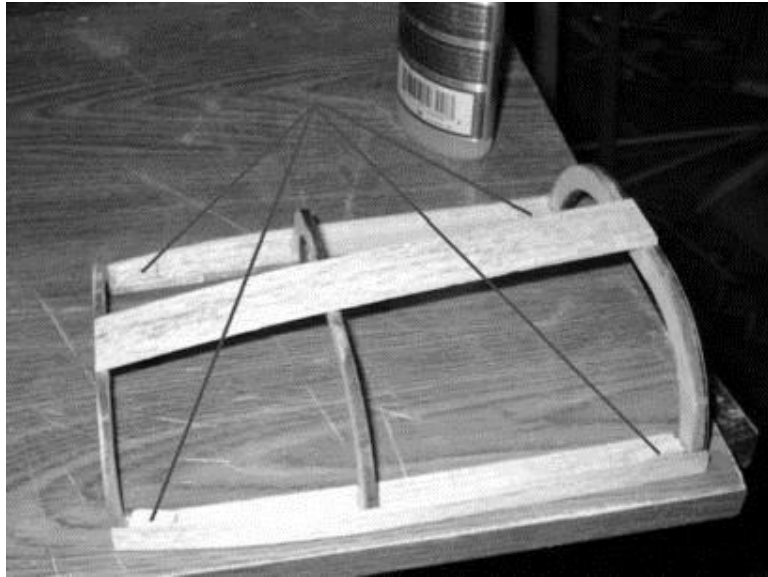

Mix some 30-minute epoxy and embed half a set into each hole, in the hatch, with epoxy. Place a piece of wax paper over the magnet and let the opposite magnet snap and hold the wax paper in position.



Apply epoxy into the holes in CR and CL, place the hatch into position, using tape to hold till cured. Remove the hatch (a single edge razor blade helps here) and remove the wax paper. Don't replace the hatch till the epoxy has a few hrs to cure.

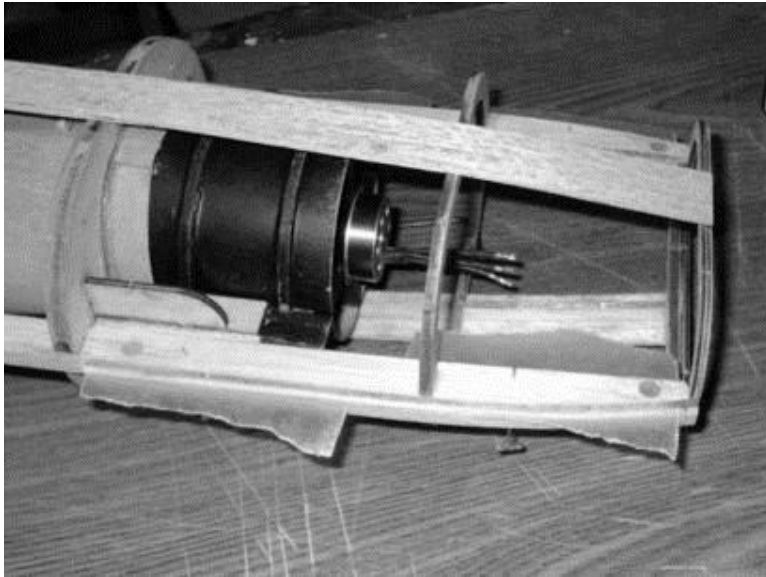

Replace the hatch. You have finished the most difficult part of this build.

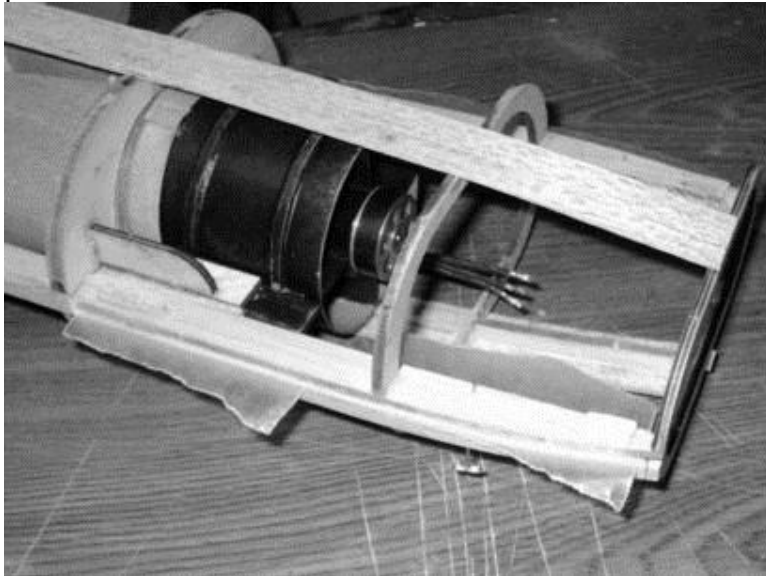

Now comes the tedious part. Go back to Step 7 and finish the fuselage planking. Install the top half of F4. And keep in mind the position of the carbon wing dowels and elevon extensions.

Step 12: Make the Nose Block and Fairings

After the planking is complete, make a paper template of the nose block from the plan. The prototype model used 7 layers of 1/8" balsa, grain running with the fuselage. One piece has the center cut out. This is the center piece. One piece on one side is only tacked. This allows taking apart the block after sanding, for hollowing. Remember, this is one design where you need to keep the nose light. So after laminating the sheets tack to F1 and begin shaping with a sanding block.

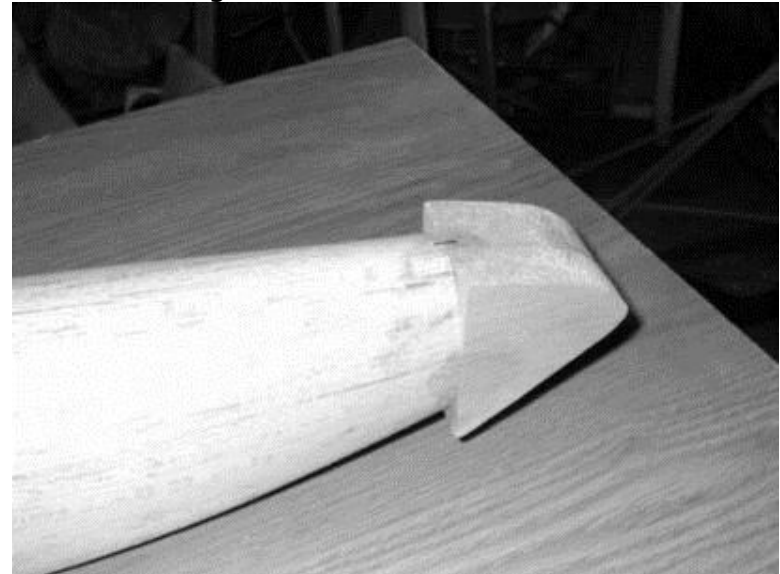

This is where the razor plane helps to knock down the excess. Hollow the block, reassemble and permanently attach to F1.



You should be able to sand the entire fuselage now. Sand 45deg to all grains, so you can cut through glue seams. Note the fairings behind the nose pod. These are done with strip wood after using the template to mark the outline. Fill all voids with spackle, the sand with fine paper. The more care you take here, the better the look of the finished product.

Try removing the hatch. You may need to help with a single edge razor in the seams. Clean the seam edges of the hatch with a block sander. And test fit the hatch a few times. It should snap into place easily. And remove with an easy pry from the razor blade. If it is tight, someday it won't come off at all. Humidity will lock it in place. To reduce this, Apply a few coats of Krylon clear to the inside of the hatch.

Step 14: All Inlets Need Nice Round Lips

Chamfer the edges of the Inlet ramps, as shown.



Position them against the inlets. Blend smoothly into the fuselage and ducting.

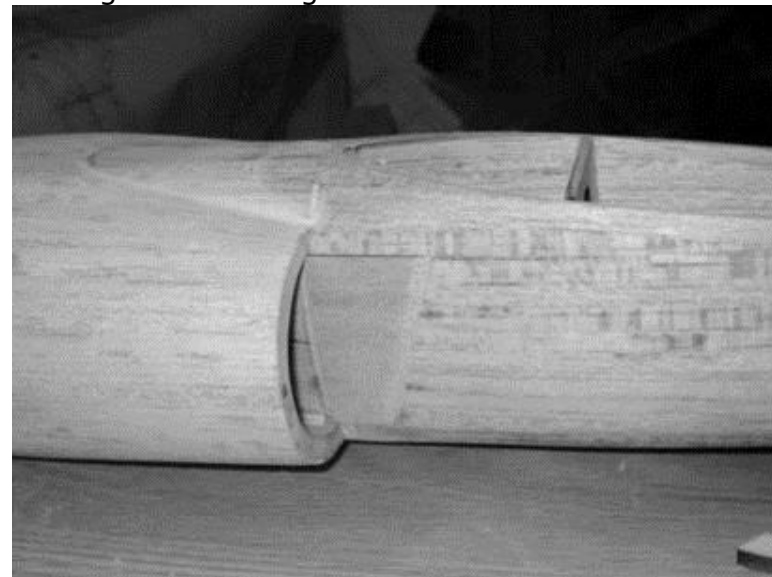

Attach two of the circular inlet blocks to each inlet, as shown. These need to match the inside of the ducting. And they are oversized to allow sanding of the "feet" to mate to the fuselage.

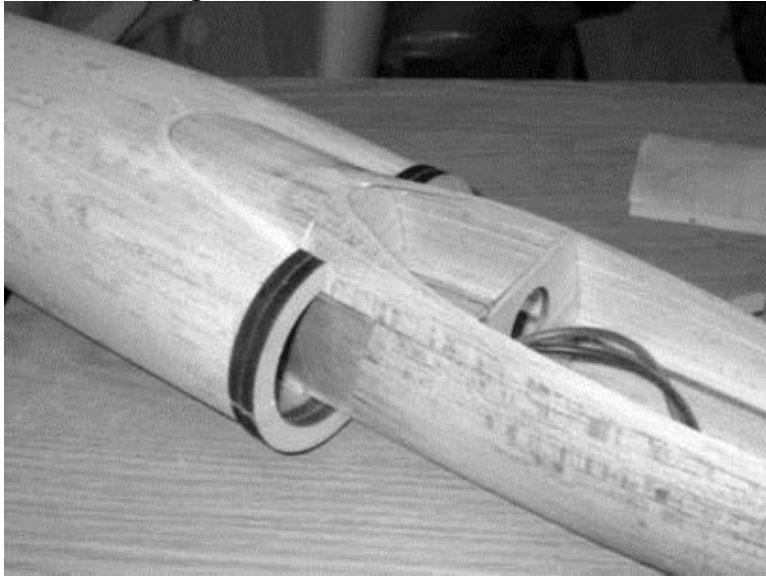

The remainder of each inlet consists of laminations of three 1/4", one 1/8" and one short 1/8" stub.

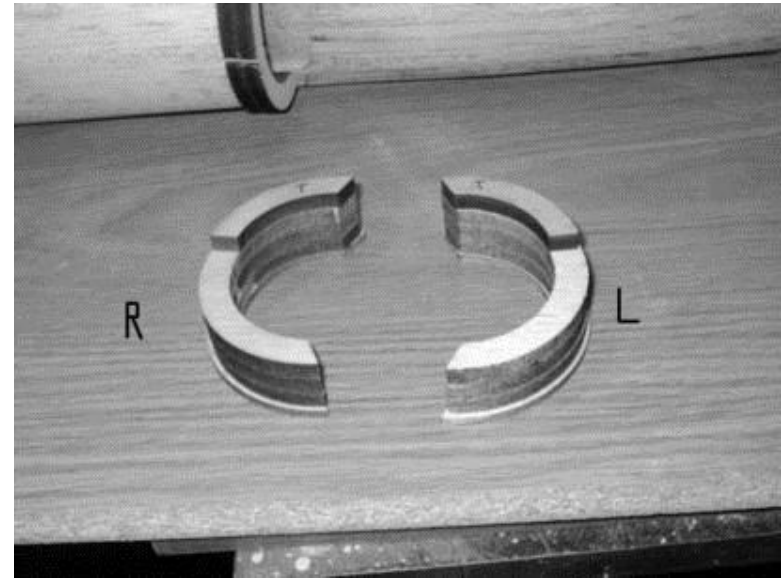

These are tapered as shown and the inside edge radiused before installing.

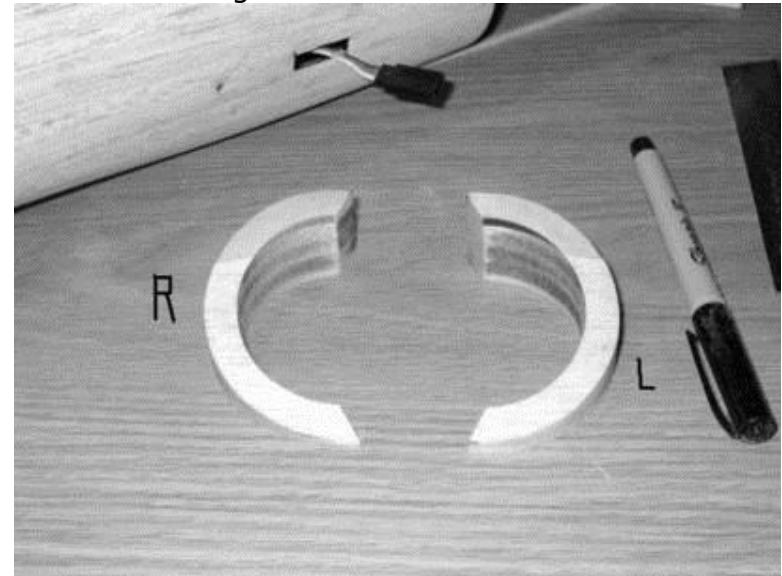

These are then installed to match the others on the INSIDE. The "feet" will have to be trimmed to fit the fuselage.

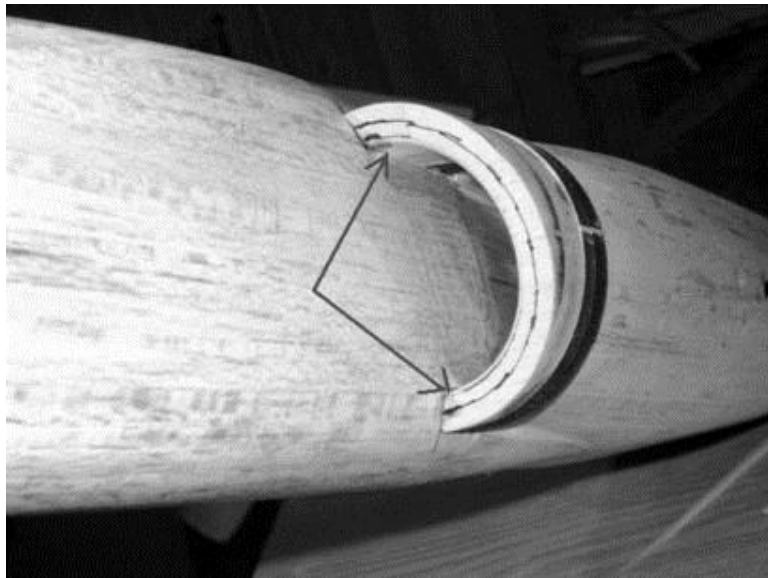

Then finish sand the outside. You should have about a 1/8" thick radiused inlet lip.

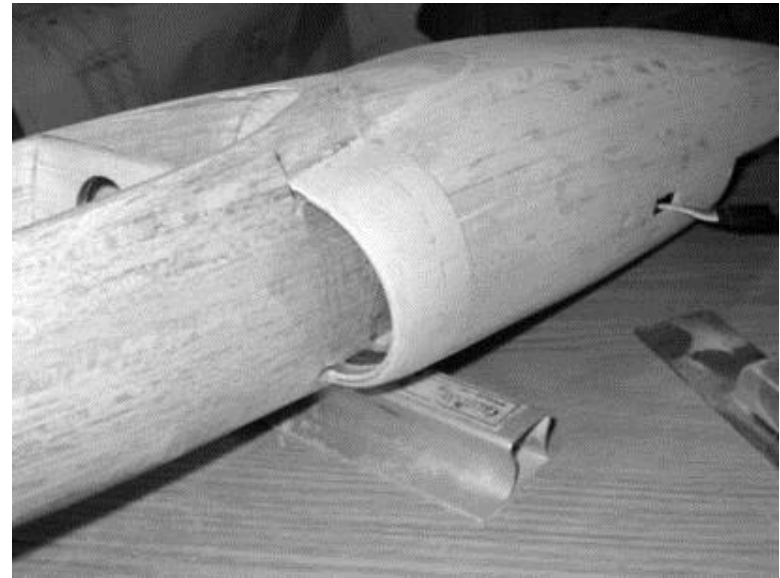

Step 15: Build the Wing

Carefully remove the tape from the wing sheeting by pulling it back on itself, at a 45 degree angle. The surface opposite the tape is the inside. Place the bottom sheeting on top of the corresponding top sheeting. Line up the panels at the TE. You should have 1/4 to 3/8" excess at the LE. Using a sanding block and 220 grit paper, sand the outside of all panels smooth using a 45 degree angle stroke. Clean the panels with a tack cloth.

Mark the rib and spar locations on the bottom sheeting. Cover the plans with waxed paper and pin the bottom sheeting in place. Install the spar at 90 degrees to the sheeting.

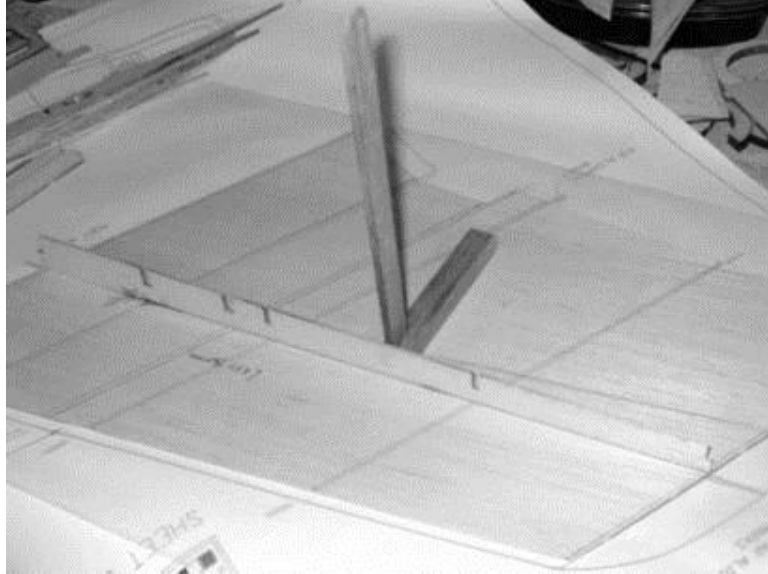

Laminate W3 and W4 using the spar and rib bottom as guide. (Note: Make left and right.) Install all ribs and elevon spars and the 1/16" false LE. False LE is lined up with the bottom of the ribs.

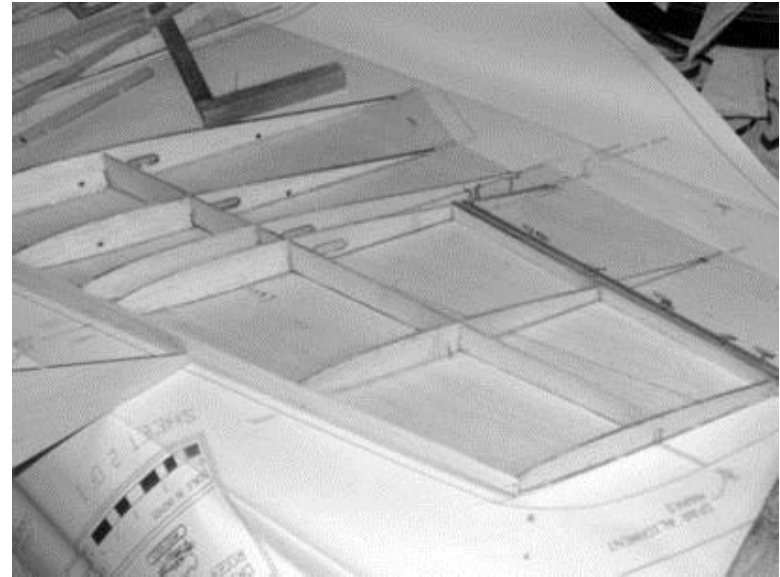

Bottom sheeting is drawn up to ribs/LE using a wedge, starting at mid wing and working out equally left and right. Use T-pins to space the elevon spars. This will reduce the chances of them being glued together later.

Remove wing from plan and finish cutting servo access free. Center the servo access mount plate and CA it to the wing skin.

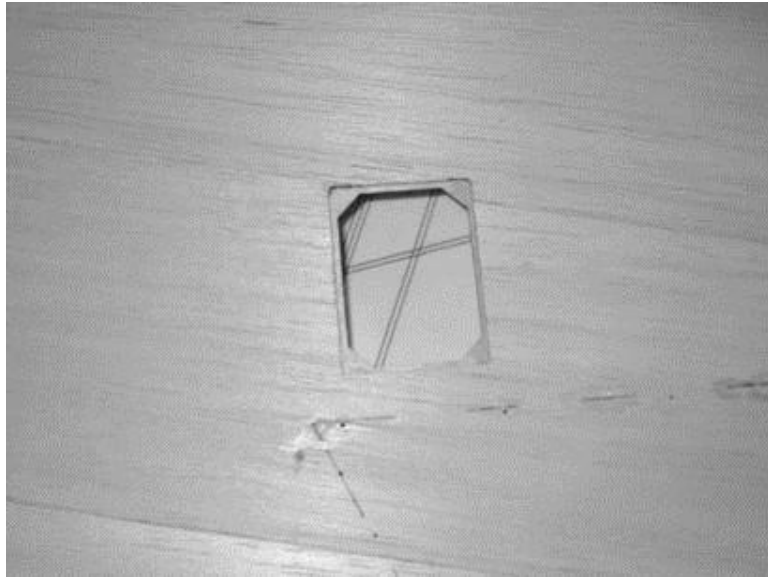

Sand the false LE to match the ribs. Install the 3/32" I.D. aluminum tubing, for the CF wing spars. Note on the plan, the position of the washout gauge. Tack glue in place. (Note: the thick end is at the wing tip.)

Chamfer the TE of the bottom sheeting to no edge. Use the edge of a hard board to help.

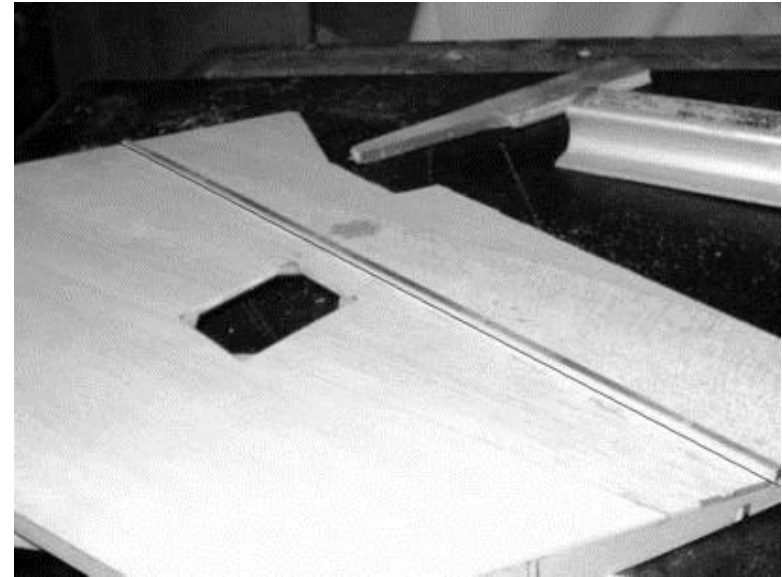
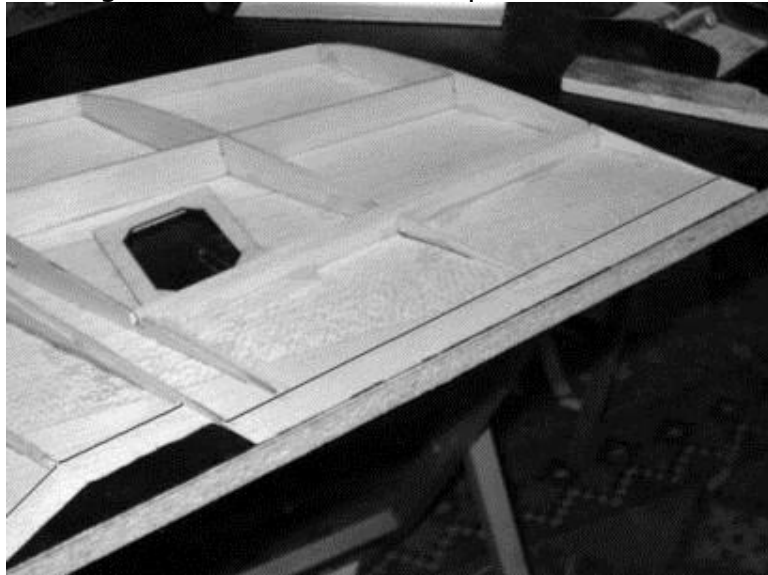

Prepare both top sheets by drawing a line as shown, 7-1/2" from the inside TE.

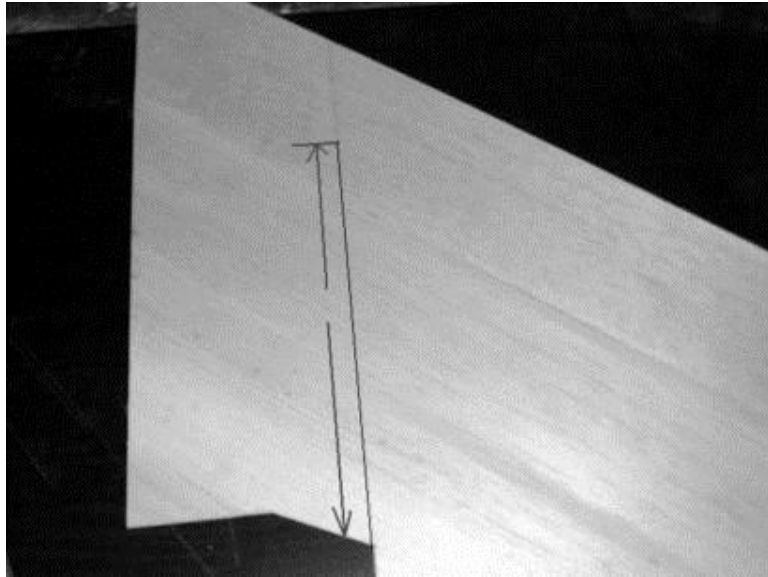

Slice with a new single edge razor. Pin the wing down flat. The TE will be raised. Place a few pieces of scrap to support the TE.

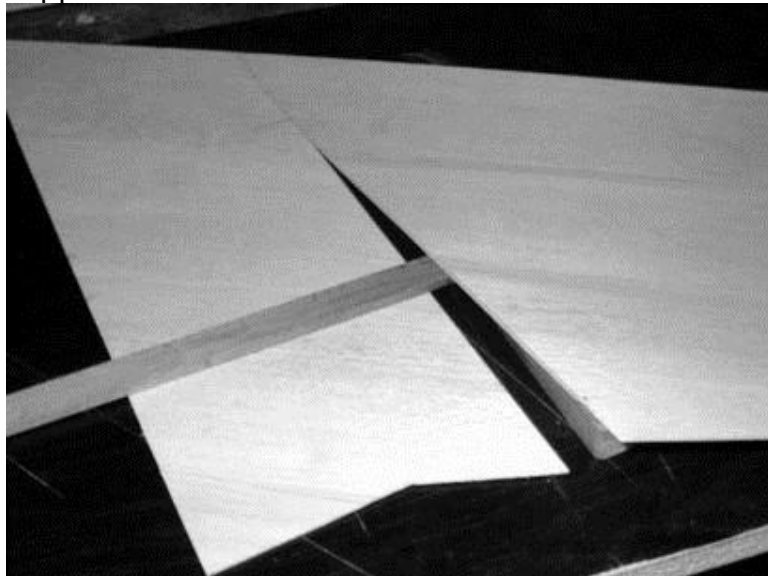

I used Gorilla PU glue on the rib tops and spar. (Avoid using the PU glue where the step is on W3 and W4. this area is CA'ed later.) Use thick CA on the TE and LE. Use the PU sparingly as it will foam. Apply the glue to the ribs and apply a bead of thick CA to the bottom TE. Line up the top TE with the bottom. Secure with kicker, then work the sheeting forward. Place bags filled with sand on the top sheeting. Use thick CA to adhere the LE. Press it down with a straight edge. Let the panel cure for four hours. Remove from table and remove the washout gauge.

Trim the sheeting at the LE and add the 1/4" LE strip. Sand the sheeting and LE flush with W1 and W7.

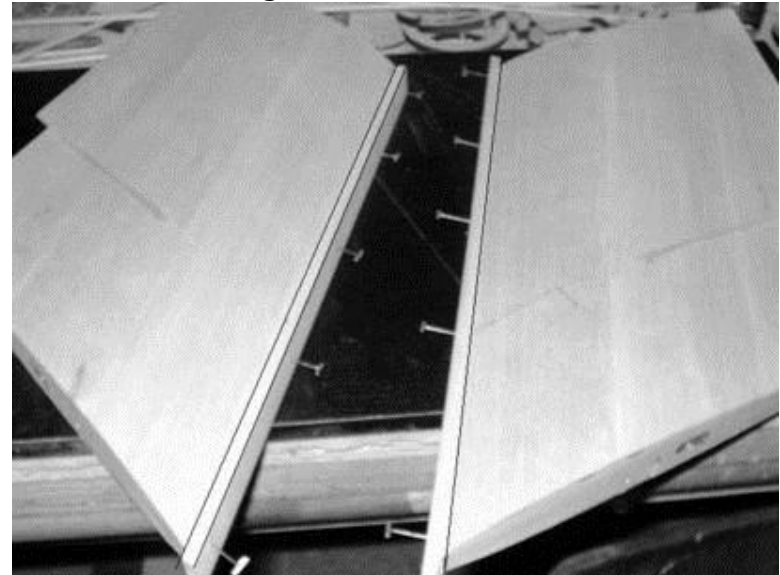

Laminate four layers of WT for each wing. Attach to the wing. Secure the top sheeting to ribs W4 and W3 with thin CA, in the step area.



Block sand the wing panels. Trial fit the vertical stabilizers to the wing. Use the plans to note placement. Sand the wing opening in the verticals to acquire a good fit. (Do not attach yet). Cut the elevons free. Use the pinholes that were made to separate the elevon spars earlier. Transfer these holes to the top sheeting to know where to cut.

After cutting the elevon free, mark the center line of the elevon LE and 1/8" on the top and bottom surface. Bevel the LE to the marked lines.

Step 16: Mount the Elevon Servos

Temporarily hinge the elevons to the wings and mount the elevon servos to the hatches. Make up the push rods. Both prototypes used .032 music wire, .032 Sullivan threaded connectors, and Dubro nylon mini-clevises. This size wire fits the micro servo horns perfectly, and they are short enough to be very stiff. Route some heavy string through the holes in the ribs so the extensions can be pulled

through when attaching the wings later. (It is suggested to mount the servos in the wing and get the elevons functioning, using either an elevon/v-tail mixer or a transmitter with elevon function. Then you know which receiver channel is to what servo, etc.)



Step 17: Finish

There are many different fan motors available and their weights can vary greatly. For this reason, construction of the battery platform and location is done after assembly and painting. The first proto had the 4s-2200 battery located between the intakes. This required using a Dremel sanding drum and reaming out F-4 and F-5. Then 3/32" hard balsa was used with a vertical balsa stop at the rear.

Note the CG location. Mark this location on the fuselage bottom, on the bottom keel. Drill a 1/8" hole. Insert a small length of inner flexible pushrod. Solder a washer into the slot of a #2x1/2" sheet metal screw. This will be used

later to balance the Cutlass, up-side-down, by screwing into the pushrod insert and hanging the Cutlass. The benefit is balancing the jet fore and aft, port and starboard. The prototype flew with no elevon trim.

It is now time to finish the surfaces using your preferred method/materials. Remember: The final finish is only as good as the wood surface under it. If using an iron on, you may chose to assemble the Cutlass first.

Step 18: Assemble the Model

Attach the vertical stabs to their proper places on the wings. Insert the CF dowels into the wing tubes and mark where the exit the wing. Insert a piece of MW into the fuselage holes, mark and add this length to the CF dowels. Fore and aft dowels will be different lengths. Epoxy the dowels into the correct wing tubes. Thread the elevon extensions into the wing as the wings are slid into the fuselage holes. Use epoxy. Note wings are not attached in the hatch area.

The design of the Cutlass allows perfect slight anhedral, by placing the fuselage on a flat surface and weighted down. The wings will rest on the ventral fins. Fill any gaps in the fuselage wing joint with spackling, sand, and then apply some thin CA to the spackle.

Make a bungee hook from 1/8" MW, drill fuselage at point shown on plan side view, and epoxy in place. A small circular scrap of 1/64 will make an excellent abrasion guard, at the base of the hook.



Use 3/16" rare earth magnets to attach the canopy base to the model. Trim the plastic canopy and attach it to the base with canopy glue. You are now ready to paint the Cutlass to choice. Decals supplied must be sealed with a few light coats of Krylon satin clear. Then apply a clear coat after decals are applied to model.

Install all equipment. Then hang Cutlass with screw apparatus. Move the battery fore or aft to balance the model, and mark the final battery location. Make up battery tray in cockpit. Use Velcro base and band to hold the battery. Locate the receiver as far forward in the cockpit as possible. Hang the Cutlass and check side to side balance. Small finishing nails work great to balance, by inserting into drilled holes in wingtip. A dab of paint hides them.

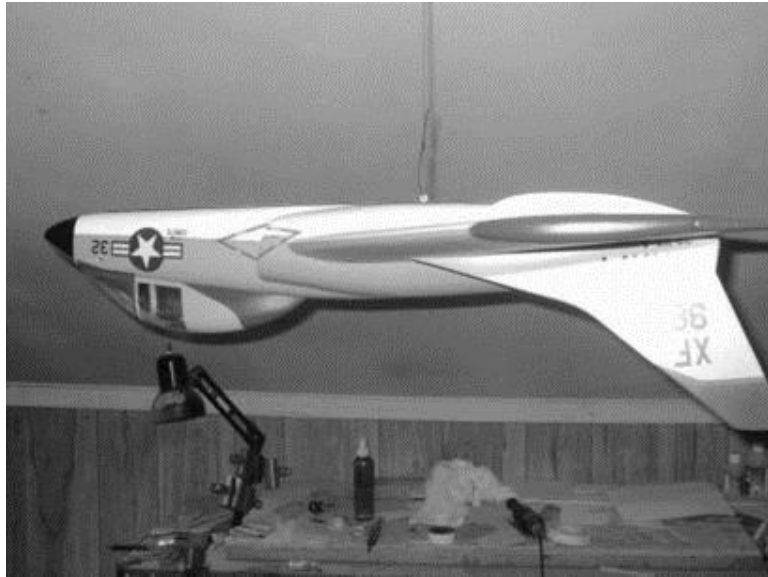

Set the control throws. Elevons should be preloaded in the up position: 1/8-3/16". The aileron throw should be 3/8" up and down, and the elevator throw should be 1/2" up and down. These can be increased to taste later. Use of exponential rates helps make the flight smoother.

First flight:

If the Cutlass is balanced properly, there should be no surprises. The prototype is launched with 10 pounds pull on the bungee and 50% power, using 550W total power. Hold approximately 50% up elevator. Climb to altitude gradually and apply any trim needed. Landings are best done in a high alpha with power on, or with a very long flat approach. The Cutlass will glide forever.

Good Luck and Enjoy your Warbirdkits.com F7U-3M Cutlass!